



## **AXFE-3514 125Mbps~155Mbps Single-mode 1550nm, SFP Transceiver**



### **Product Overview**

The AXFE-3514 family of Small Form Factor Pluggable (SFP) transceiver module is specifically designed for the high performance integrated duplex data link over single-mode optical fiber. These transceiver modules are compliant with the SFP Multisource Agreement (MSA). With the hot pluggability, these modules offer an easy way to be installed into SFP MSA compliant ports at any time without the interruption of the host equipments operating online.

The AXFE-3514 SFP transceivers using a long wavelength (1550nm) DFB laser diode enable data transmission up to 120km on a single-mode (9/125 $\mu$ m) optical fiber.

### **Features**

- **SFP Multi-Source Agreement compliant**
- **125Mbps IEEE802.3ah 100BASE-LX10**
- **155Mbps ITU-T G957 L-1.2 compliant**
- **155Mbps SONET OC-3 LR-2 compliant**
- **Serial ID functionality support**
- **AC-coupled differential inputs and outputs**
- **Class 1 laser safety standard IEC 825 compliant**
- **100/120 km link on a single-mode fiber**
- **Low power dissipation**

### **Applications**

- **ATM switches and routers**
- **Fast Ethernet**
- **SONET/SDH switch infrastructure**

**Block diagram**

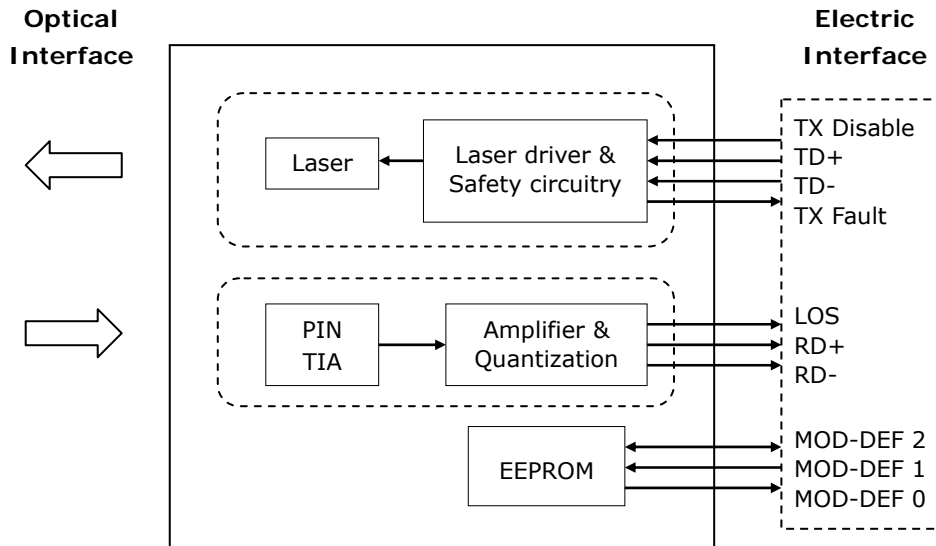

The transceiver is fundamentally consisted by two parts: transmitter and receiver. The transmitter features a TTL logic level Disable signal and a Fault indicator. The receiver features a TTL logic Loss of Signal (LOS) detection. For the access of serial identification information, an EEPROM is used to store the required data via the 2-wire serial CMOS EEPROM protocol. The detailed signal descriptions are listed in the following sections.

**Absolute Maximum Ratings**

Parameter	Symbol	Min.	Max.	Unit	Note
Storage Temperature	T <sub>s</sub>	-40	+85	°C	
Supply Voltage	V <sub>ccT</sub> V <sub>ccR</sub>	-0.5	4.0	V	
Storage Relative Humidity	RH	5	95	%	

**Recommended Operating Conditions**

Parameter	Symbol	Min.	Typ.	Max.	Unit	Note
Case Operating Temperature	T <sub>c</sub>	0		70	°C	Refer to ordering information
		-40		85		
Supply Voltage	V <sub>cc</sub>	3.1	3.3	3.5	V	
Supply Current	I <sub>TX</sub> + I <sub>RX</sub>		150	300	mA	

### Transmitter Electro-Optical Interface

Parameter		Symbol	Min.	Typ.	Max.	Unit	Note
Transmitter Differential Input Voltage		TD +/-	400		2400	mV	
Tx_Fault - High		V <sub>Fault_H</sub>	2		V <sub>CC</sub>	V	
Tx_Fault - Low		V <sub>Fault_L</sub>	V <sub>ee</sub>		V <sub>ee</sub> +0.8	V	
Tx_Disable - High		V <sub>Disable_H</sub>	2		V <sub>CC</sub>	V	
Tx_Disable - Low		V <sub>Disable_L</sub>	V <sub>ee</sub>		V <sub>ee</sub> +0.8	V	
Optical Output Power	100 km	P <sub>O</sub>	-5		0	dBm	
	120 km		0		+5		
Optical Extinction Ratio		E <sub>R</sub>	10			dB	
Center Wavelength		λ <sub>C</sub>	1530	1550	1570	nm	
Spectral Width (-20dB)		Δλ			1	nm	
Optical Rise / Fall Time		t <sub>r</sub> / t <sub>f</sub>			2	nsec	1

**Notes:**

1. 10% to 90% value

### Receiver Electro-Optical Characteristics

Parameter		Symbol	Min.	Typ.	Max.	Unit	Note
Receiver Differential Output Voltage		RD +/-	400		2000	mV	
Receiver Overload		P <sub>INMAX</sub>	0			dBm	1
Receiver Sensitivity		P <sub>INMIN</sub>			-35	dBm	1
Operating Center Wavelength		λ <sub>C</sub>	1260		1600	nm	
Receiver Loss of Signal - TTL Low		P <sub>RX_LOSD</sub>			-35	dBm	
Receiver Loss of Signal - TTL High		P <sub>RX_LOSA</sub>	-45			dBm	
Receiver Loss of Signal - Hysteresis		P <sub>RX_LOSH</sub>	1.0			dB	

**Notes:**

1. With BER better than or equal to  $1 \times 10^{-12}$ , measured in the center of the eye opening with  $2^7 - 1$  PRBS

### Pin Description

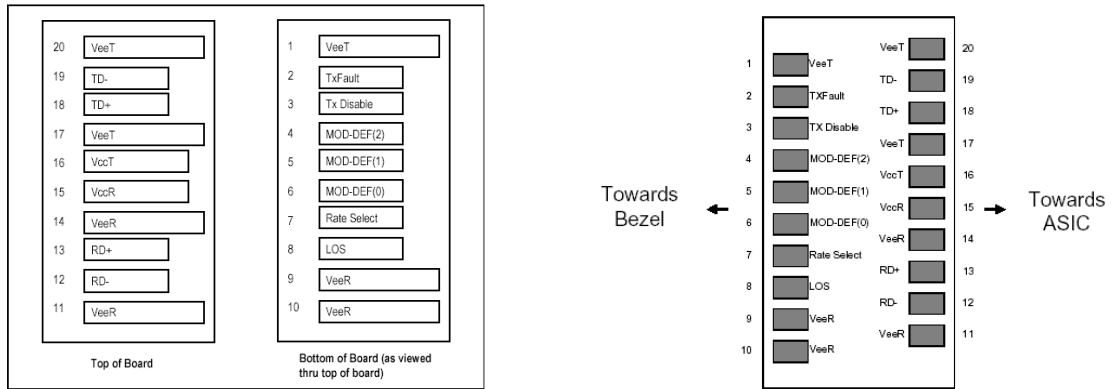

SFP Transceiver Electric Pad Layout

Diagram of Host Board Connector Block Pin Numbers and Names

Pin No	Pin Name	Function	Plug Seq.	Notes
1	VeeT	Transmitter Ground	1	
2	TX Fault	Transmitter Fault Indication	3	1
3	TX Disable	Transmitter Disable	3	2
4	MOD-DEF 2	Module Definition 2	3	3
5	MOD-DEF 1	Module Definition 1	3	3
6	MOD-DEF 0	Module Definition 0	3	3
7	Rate Select	Select between full or reduced receiver bandwidth	3	4
8	LOS	Loss of Signal	3	5
9	VeeR	Receiver Ground	1	6
10	VeeR	Receiver Ground	1	6
11	VeeR	Receiver Ground	1	6
12	RD -	Inv. Received Data Out	3	7
13	RD +	Received Data Out	3	7
14	VeeR	Receiver Ground	1	6
15	VccR	Receiver Power	2	8
16	VccT	Transmitter Power	2	8
17	VeeT	Transmitter Ground	1	6
18	TD +	Transmit Data In	3	9
19	TD -	Inv. Transmit Data In	3	9
20	VeeT	Transmitter Ground	1	6



**Notes:**

Plug Seq.: Pin engagement sequence during hot plugging.

1. TX Fault is an open collector/drain output, which should be pulled up with a 4.7K – 10K $\Omega$  resistor on the host board. Pull up voltage between 2.0V and VccT, R+0.3V. When high, output indicates a laser fault of some kind. Low indicates normal operation. In the low state, the output will be pulled to < 0.8V.
2. TX disable is an input that is used to shut down the transmitter optical output. It is pulled up within the module with a 4.7 – 10 K $\Omega$  resistor. Its states are:  
Low (0 – 0.8V): Transmitter on  
(>0.8, < 2.0V): Undefined  
High (2.0 – 3.465V): Transmitter Disabled  
Open: Transmitter Disabled
3. Mod-Def 0,1,2. These are the module definition pins. They should be pulled up with a 4.7K - 10K $\Omega$  resistor on the host board. The pull-up voltage shall be VccT or VccR  
Mod-Def 0 is grounded by the module to indicate that the module is present  
Mod-Def 1 is the clock line of two wire serial interface for serial ID  
Mod-Def 2 is the data line of two wire serial interface for serial ID
4. This is an optional input used to control the receiver bandwidth for compatibility with multiple data rates (most likely Fiber Channel 1x and 2x Rates). If implemented, the input will be internally pulled down with > 30k $\Omega$  resistor. The input states are:  
Low (0 - 0.8V): Reduced Bandwidth  
(>0.8 , < 2.0V): Undefined  
High (2.0 V -3.465V): Full Bandwidth  
Open: Reduced Bandwidth
5. LOS (Loss of Signal) is an open collector/drain output, which should be pulled up with a 4.7K -10K $\Omega$  resistor. Pull up voltage between 2.0V and VccT, R+0.3V. When high, this output indicates the received optical power is below the worst-case receiver sensitivity (as defined by the standard in use). Low indicates normal operation. In the low state, the output will be pulled to < 0.8V.
6. VeeR and VeeT may be internally connected within the SFP module.
7. RD-/+: These are the differential receiver outputs. They are AC coupled 100 $\Omega$  differential lines which should be terminated with 100 $\Omega$  (differential) at the user SERDES. The AC coupling is done inside the module and is thus not required on the host board. The voltage swing on these lines will be between 370 and 2000 mV differential (185 - 1000 mV single ended) when properly terminated.
8. VccR and VccT are the receiver and transmitter power supplies. They are defined as 3.3V  $\pm$ 5% at the SFP connector pin. Maximum supply current is 300 mA. Recommended host board power supply filtering is shown below. Inductors with DC resistance of less than 1 $\Omega$  should be used in order to maintain the required voltage at the SFP input pin with 3.3V supply voltage. When the recommended supply filtering network is used, hot plugging of the SFP transceiver module will result in an inrush current of no more than 30 mA greater than the steady state value. VccR and VccT may be internally connected within the SFP transceiver module.
9. TD-/+: These are the differential transmitter inputs. They are AC-coupled, differential lines with 100 $\Omega$  differential termination inside the module. The AC coupling is done inside the module and is thus not required on the host board. The inputs will accept differential swings of 500 mV - 2400 mV (250 mV - 1200 mV single-ended), though it is recommended that values between 500 and 1200 mV differential (250 mV- 600 mV single-ended) be used for best EMI performance.

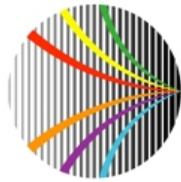

## Mechanical Dimensions (Units in mm)

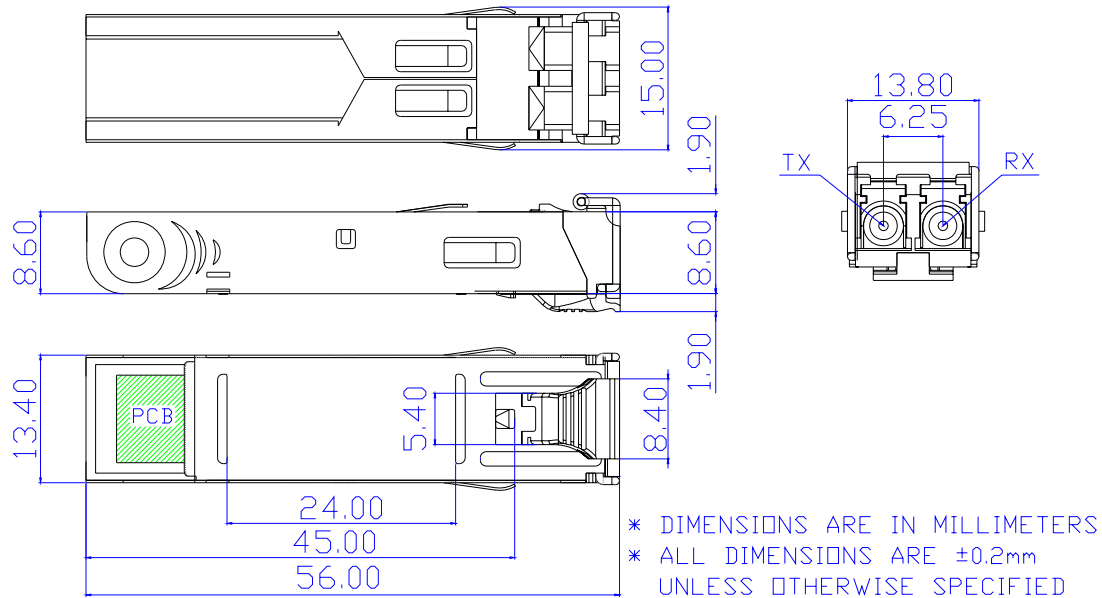

## Ordering Information

**AXFE-3514-05xy**

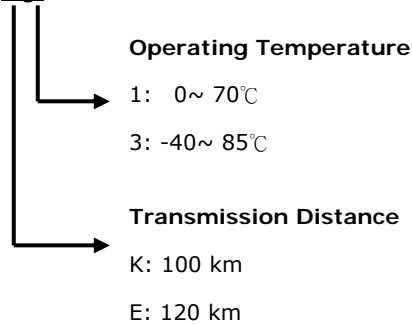

Model No.	Wavelength	LD	I/O	LOS	Link	Temp.
AXFE-3514-05K1	1550nm	DFB	AC/AC	TTL	100km	0~70°C
AXFE-3514-05K3	1550nm	DFB	AC/AC	TTL	100km	-40~85°C
AXFE-3514-05E1	1550nm	DFB	AC/AC	TTL	120km	0~70°C
AXFE-3514-05E3	1550nm	DFB	AC/AC	TTL	120km	-40~85°C

### NOTE:

Distances are indicative only. Attenuation of 0.25 dB/km is used for the link length calculations. To calculate a more precise link budget based on specific conditions in your application, please refer to the Optical Specifications in Page#3.