



AXFD-58D4 4.25Gbps Multimode 850nm, SFP Transceiver with Monitoring Interface



Product Overview

The AXFD-58D4 family of Small Form Factor Pluggable (SFP) transceiver module is specifically designed for the high performance integrated duplex data link over multimode optical fiber. These transceiver modules are compliance with the SFP Multisource Agreement (MSA). An enhanced Digital Diagnostic Monitoring Interface has been incorporated into the Axcen SFP Transceiver. Real time monitors of temperature, supply voltage, laser bias current, laser average output power and received output power are provided, based on the SFF-8472.

The AXFD-58D4 SFP transceivers using a short wavelength (850nm) VCSEL laser diode enable data transmission up to 150m on a multimode 50/125 μ m optical fiber and 70m on a multimode 62.5/125 μ m optical fiber.

Features

- **SFP Multi-Source Agreement compliant**
- **LC duplex receptacle**
- **4.25Gbps Fibre Channel FC-PI-2 400-M5-SN-I compliant**
- **4.25Gbps Fibre Channel FC-PI-2 400-M6-SN-I compliant**
- **1.25Gbps IEEE 802.3z 1000Base-SX compliant**
- **Single +3.3V power supply**
- **Class 1 laser safety standard IEC 825 compliant**
- **150m link on a multimode fiber**
- **Low power dissipation**

Applications

- **1.063/2.125/4.25Gbps Fibre Channel**
- **1.25Gbps Gigabit Ethernet**



Block diagram

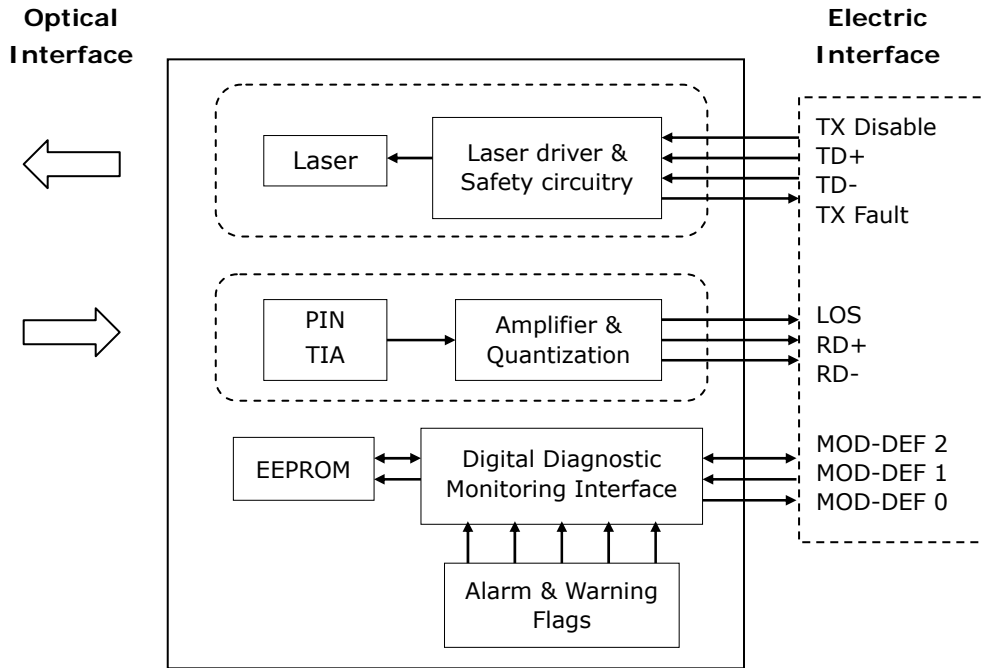

The transceiver is fundamentally consisted by two parts: transmitter and receiver. The transmitter features a TTL logic level Disable signal and a Fault indicator. The receiver features a TTL logic Loss of Signal (LOS) detection. The serial ID interface defines a 256-byte memory map in EEPROM, accessible over a 2 wire, serial interface at the 8 bit address 1010000X (A0h). The Digital Diagnostic Monitoring Interface makes use of the 8 bit address 1010001X (A2h), so the originally defined serial ID memory map remains unchanged and is therefore backward compatible. The detailed signal descriptions are listed in the following sections.

Absolute Maximum Ratings

Parameter	Symbol	Min.	Max.	Unit	Note
Storage Temperature	T _s	-40	+85	°C	
Supply Voltage	V _{ccT} V _{ccR}	-0.5	4.0	V	
Storage Relative Humidity	RH	5	95	%	



Recommended Operating Conditions

Parameter	Symbol	Min.	Typ.	Max.	Unit	Note
Case Operating Temperature	T_C	0		70	°C	Refer to ordering information
		-40		85		
Supply Voltage	V_{CC}	3.1	3.3	3.5	V	
Supply Current	$I_{TX} + I_{RX}$		180	300	mA	

Transmitter Electro-Optical Interface

Parameter	Symbol	Min.	Typ.	Max.	Unit	Note
Transmitter Differential Input Voltage	TD +/-	400		2400	mVp-p	
Tx_Fault - High	V_{Fault_H}	2		V_{CC}	V	
Tx_Fault - Low	V_{Fault_L}	V_{EE}		$V_{EE}+0.8$	V	
Tx_Disable -High	$V_{Disable_H}$	2		V_{CC}	V	
Tx_Disable - Low	$V_{Disable_L}$	V_{EE}		$V_{EE}+0.8$	V	
Optical Output Power	P_o	-9		0	dBm	1
Optical Extinction Ratio	E_R	9			dB	
Optical Modulation Amplitude	OMA	0.247			mW	
Center Wavelength	λ_C	830	850	860	nm	
Spectral Width (RMS)	$\Delta\lambda$			0.85	nm	
Optical Rise / Fall Time	t_r / t_f			90	ps	2
Relative Intensity Noise (OMA)	RIN_{12}			-118	dB/Hz	
Total Jitter @ 1.063Gb/s, 1.25Gb/s	TJ			0.43	UI	3
Total Jitter @ 2.125Gb/s				0.44		
Total Jitter @ 4.25Gb/s				0.44		

Notes:

1. Coupling into a 50/125 μ m multimode fiber.
2. 20% to 80% value
3. Total jitter is specified at the 10^{-12} probability

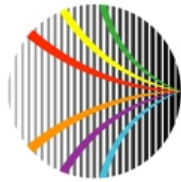

Receiver Electro-Optical Interface

Parameter	Symbol	Min.	Typ.	Max.	Unit	Note
Receiver Differential Output Voltage	RD +/-	400		2000	mVp-p	
Receiver Overload	P _{IN} MAX	0			dBm	1
Receiver Sensitivity @ 1.063Gb/s	P _{IN} MIN			-19	dBm	1
Receiver Sensitivity @ 1.25Gb/s				-19		
Receiver Sensitivity @ 2.125Gb/s				-17		
Receiver Sensitivity @ 4.25Gb/s				-15		
Operating Center Wavelength	λ _c	830		860	nm	
Return Loss	RL	12			dB	
Receiver Loss of Signal - TTL Low	P _{RX_LOSD}			-19	dBm	
Receiver Loss of Signal - TTL High	P _{RX_LOSA}	-31			dBm	
Receiver Loss of Signal - Hysteresis	P _{RX_LOSH}	0.5			dB	

Notes:

1. With BER better than or equal to 1×10^{-12} , measured in the center of the eye opening with $2^7 - 1$ PRBS

Digital Diagnostic Memory Map

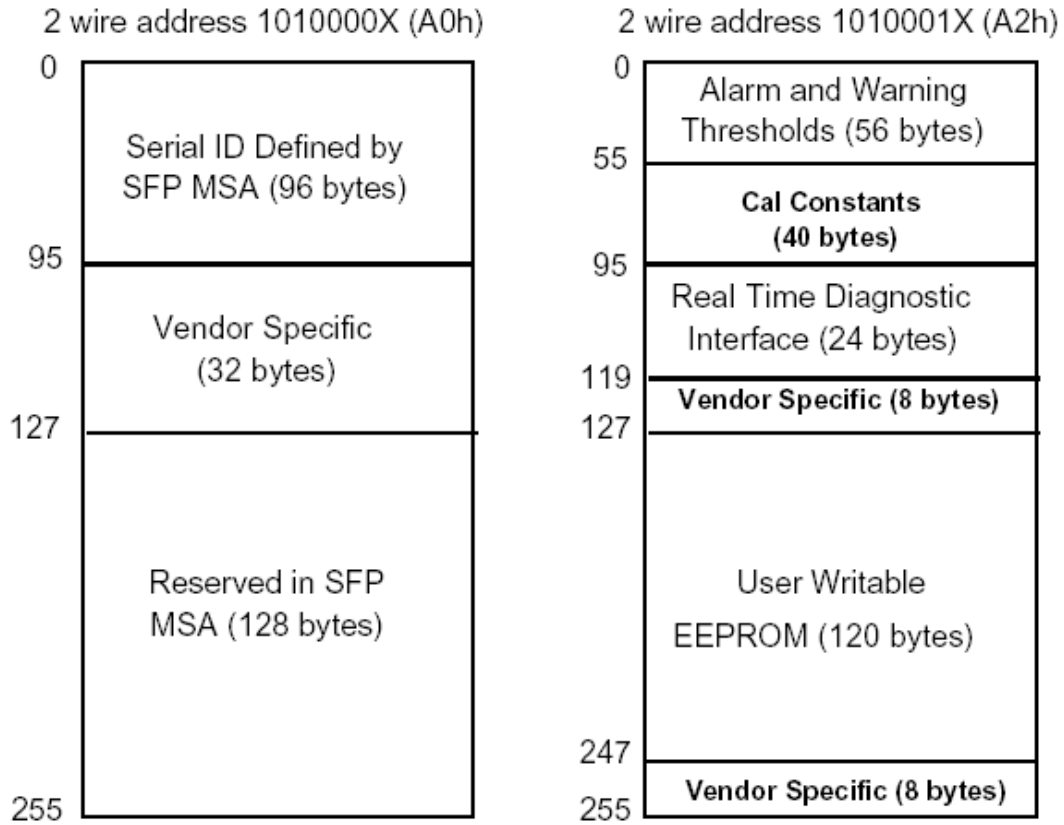

Digital Diagnostic Monitoring Characteristics

Parameter	Symbol	Accuracy	Unit	Note
Transceiver Temperature	T _{INT}	±3	°C	
Transceiver Supply Voltage	V _{INT}	±3	%	
TX Bias Current	I _{BIAS}	±10	%	
TX Output Power	P _{TX}	±3	dB	
RX Received Optical Power	P _{RX}	±3	dB	

Pin Description

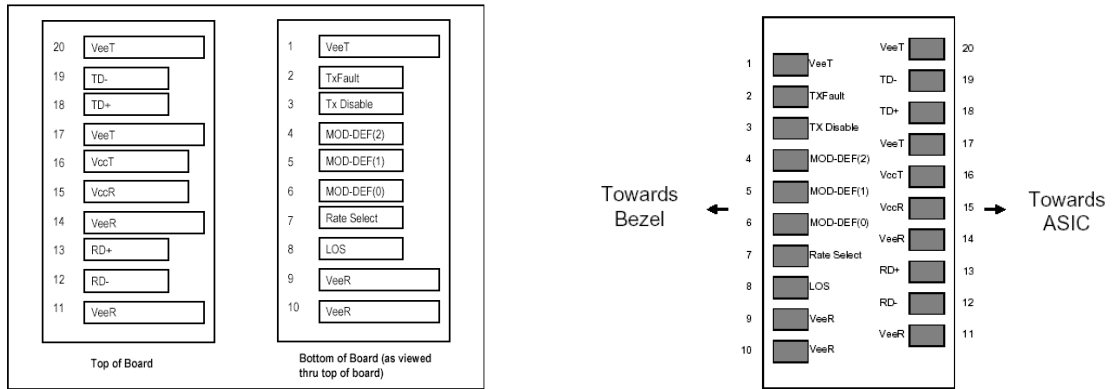

SFP Transceiver Electric Pad Layout

Diagram of Host Board Connector Block Pin Numbers and Names

Pin No.	Pin Name	Function	Plug Seq.	Notes
1	V _{ee} T	Transmitter Ground	1	
2	TX Fault	Transmitter Fault Indication	3	1
3	TX Disable	Transmitter Disable	3	2
4	MOD-DEF 2	Module Definition 2	3	3
5	MOD-DEF 1	Module Definition 1	3	3
6	MOD-DEF 0	Module Definition 0	3	3
7	Rate Select	Select between full or reduced receiver bandwidth	3	4
8	LOS	Loss of Signal	3	5
9	V _{ee} R	Receiver Ground	1	6
10	V _{ee} R	Receiver Ground	1	6
11	V _{ee} R	Receiver Ground	1	6
12	RD -	Inv. Receiver Data Out	3	7
13	RD +	Receiver Data Out	3	7
14	V _{ee} R	Receiver Ground	1	6
15	V _{cc} R	Receiver Power	2	8
16	V _{cc} T	Transmitter Power	2	8
17	V _{ee} T	Transmitter Ground	1	6
18	TD +	Transmitter Data In	3	9
19	TD -	Inv. Transmitter Data In	3	9
20	V _{ee} T	Transmitter Ground	1	6



Notes:

Plug Seq.: Pin engagement sequence during hot plugging.

1. TX Fault is an open collector/drain output, which should be pulled up with a 4.7K – 10K Ω resistor on the host board. Pull up voltage between 2.0V and VccT, R+0.3V. When high, output indicates a laser fault of some kind. Low indicates normal operation. In the low state, the output will be pulled to < 0.8V.
2. TX disable is an input that is used to shut down the transmitter optical output. It is pulled up within the module with a 4.7 – 10 K Ω resistor. Its states are:
Low (0 – 0.8V): Transmitter on
(>0.8, < 2.0V): Undefined
High (2.0 – 3.465V): Transmitter Disabled
Open: Transmitter Disabled
3. Mod-Def 0,1,2. These are the module definition pins. They should be pulled up with a 4.7K - 10K Ω resistor on the host board. The pull-up voltage shall be VccT or VccR
Mod-Def 0 is grounded by the module to indicate that the module is present
Mod-Def 1 is the clock line of two wire serial interface for serial ID
Mod-Def 2 is the data line of two wire serial interface for serial ID
4. This is an optional input used to control the receiver bandwidth for compatibility with multiple data rates (most likely Fiber Channel 1x and 2x Rates). If implemented, the input will be internally pulled down with > 30k Ω resistor. The input states are:
Low (0 - 0.8V): Reduced Bandwidth
(>0.8 , < 2.0V): Undefined
High (2.0 V -3.465V): Full Bandwidth
Open: Reduced Bandwidth
5. LOS (Loss of Signal) is an open collector/drain output, which should be pulled up with a 4.7K -10K Ω resistor. Pull up voltage between 2.0V and VccT, R+0.3V. When high, this output indicates the received optical power is below the worst-case receiver sensitivity (as defined by the standard in use). Low indicates normal operation. In the low state, the output will be pulled to < 0.8V.
6. VeeR and VeeT may be internally connected within the SFP module.
7. RD-/+ : These are the differential receiver outputs. They are AC coupled 100 Ω differential lines which should be terminated with 100 Ω (differential) at the user SERDES. The AC coupling is done inside the module and is thus not required on the host board. The voltage swing on these lines will be between 370 and 2000 mV differential (185 - 1000 mV single ended) when properly terminated.
8. VccR and VccT are the receiver and transmitter power supplies. They are defined as 3.3V \pm 5% at the SFP connector pin. Maximum supply current is 300 mA. Recommended host board power supply filtering is shown below. Inductors with DC resistance of less than 1 Ω should be used in order to maintain the required voltage at the SFP input pin with 3.3V supply voltage. When the recommended supply filtering network is used, hot plugging of the SFP transceiver module will result in an inrush current of no more than 30 mA greater than the steady state value. VccR and VccT may be internally connected within the SFP transceiver module.
9. TD-/+ : These are the differential transmitter inputs. They are AC-coupled, differential lines with 100 Ω differential termination inside the module. The AC coupling is done inside the module and is thus not required on the host board. The inputs will accept differential swings of 500 mV - 2400 mV (250 mV - 1200 mV single-ended), though it is recommended that values between 500 and 1200 mV differential (250 mV- 600 mV single-ended) be used for best EMI performance.

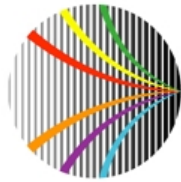

Mechanical Dimensions (Units in mm)

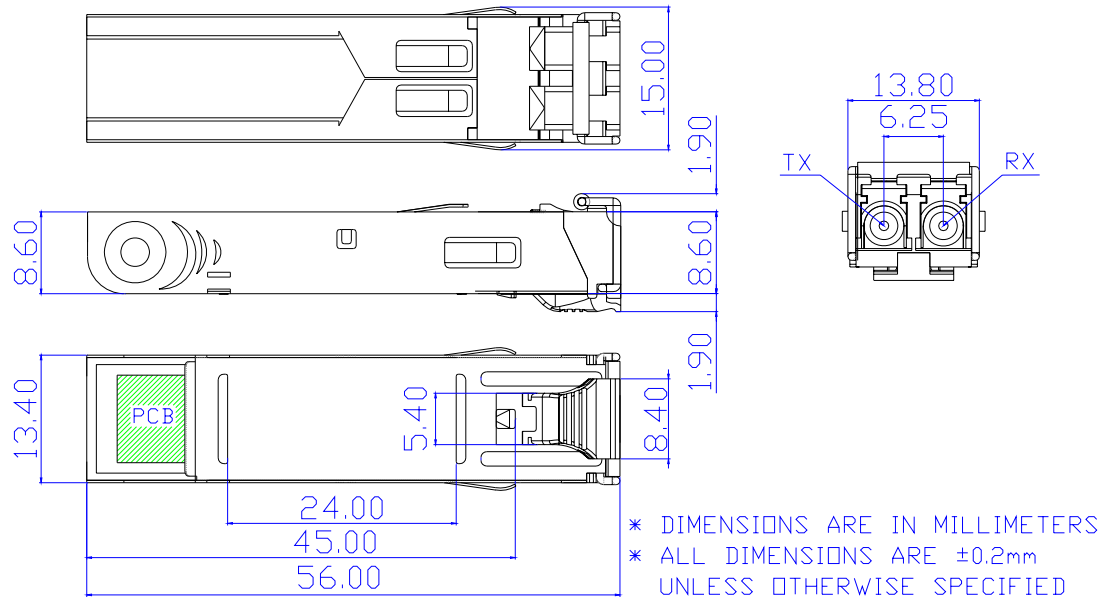

Ordering Information

AXFD-58D4-05L_x



Operating Temperature

1: 0~70°C

3: -40~85°C

Model No.	Wavelength	LD	I/O	LOS	Link	Temp.
AXFD-58D4-05L1	850nm	VCSEL	AC/AC	TTL	150m	0~70°C
AXFD-58D4-05L3	850nm	VCSEL	AC/AC	TTL	150m	-40~85°C