



AXFT-1613 125Mbps Single Fiber Bi-directional, 2x5 SFF, SC Receptacle, ONU Transceiver



Product Overview

The AXFT-1613 family of Small Form Factor (SFF) transceiver module is specifically designed for the high performance integrated duplex data link over single-mode optical fiber. These transceiver modules are compliant with the SFF Multisource Agreement (MSA).

The AXFT-1613 BiDi SFF transceivers using a long wavelength (1310nm) FP laser diode and a 1550nm PIN for receiver enable data transmission up to 20km on a single-mode (9/125 μ m) optical fiber.

Features

- **125Mbps~155Mbps bi-directional single fiber link**
- **Single SC receptacle**
- **1310nm FP transmitter, 1550nm PIN receiver**
- **20km point-to-point transmission**
- **125Mbps IEEE 802.3ah 100BASE-BX10-U compliant**
- **155Mbps OC-3 IR-1/STM S-1.1 compliant**
- **SFF Multi-Source Agreement compliant**
- **Class 1 laser safety standard IEC 60825 compliant**
- **Low power dissipation**

Applications

- **FTTx**
- **Fast Ethernet**
- **ATM switches and routers**
- **SONET/SDH switch infrastructure**

Block diagram

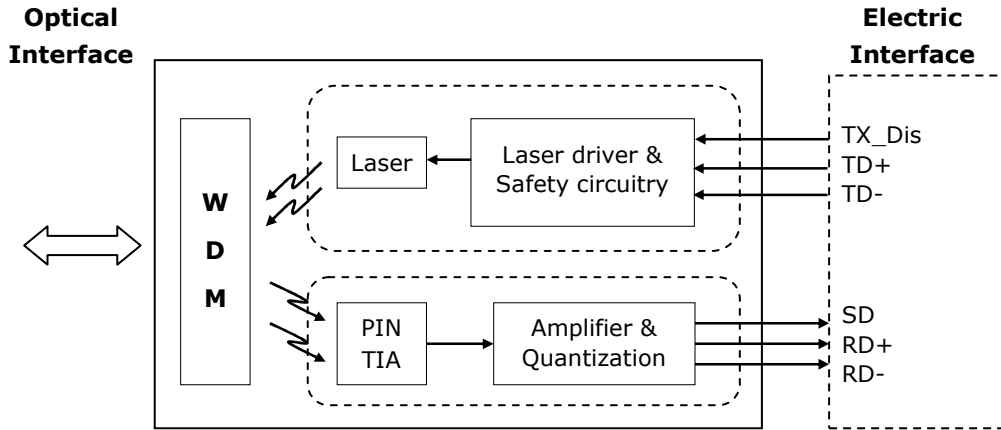

The transceiver is fundamentally consisted by two parts: transmitter and receiver. The transmitter features LVPECL differential data inputs (TD+ and TD-) and an LVTTTL for TX disable control (TX_Dis). The receiver features LVPECL differential data outputs (RD+ and RD-) and LVPECL for signal detect output (SD).

Absolute Maximum Ratings

Parameter	Symbol	Min.	Max.	Unit	Note
Storage Temperature	T _S	-40	+85	°C	
Supply Voltage	V _{CC}	-0.5	+4.0	V	
Storage Relative Humidity	RH	5	95	%	
Soldering Temperature / Time	T _{SOLD} / t _{SOLD}		260/10	°C/sec	

Recommended Operating Conditions

Parameter	Symbol	Min.	Typ.	Max.	Unit	Note
Case Operating Temperature	T _C	0		70	°C	Refer to ordering information
		-40		+85		
Supply Voltage	V _{CC} T V _{CC} R	3.1	3.3	3.5	V	
Supply Current	I _{TX} +I _{RX}		150	300	mA	



Transmitter Electro-Optical Interface

Parameter	Symbol	Min.	Typ.	Max.	Unit	Note
Data Input Voltage – Low	V_L-V_{CC}	-1.81		-1.475	V	
Data Input Voltage – High	V_H-V_{CC}	-1.165		-0.88	V	
Tx_Disable - High	$V_{Disable_H}$	2		$V_{CC}T$	V	
Tx_Disable - Low	$V_{Disable_L}$	$V_{EE}T$		$V_{EE}T+0.8$	V	
Tx_Disable Assert Time	T_{ASSERT}			10	μs	
Tx_Disable Deassert Time	$T_{DEASSERT}$			1.0	ms	
Optical Output Power	P_o	-14		-8	dBm	1
Optical Extinction Ratio	E_R	8.2			dB	
Center Wavelength	λ_c	1260	1310	1360	nm	
Spectral Width (RMS)	$\Delta\lambda$			4	nm	
Optical Rise Time	t_r			2	ns	
Optical Fall Time	t_f			2	ns	

Notes:

1. Coupling into a 9/125 μm single-mode fiber.

Receiver Electro-Optical Interface

Parameter	Symbol	Min.	Typ.	Max.	Unit	Note
Receiver Overload	P_{INMAX}	0			dBm	1
Receiver Sensitivity	P_{INMIN}			-32	dBm	1
Operating Center Wavelength	λ_c	1480		1600	nm	
Return Loss	RL	12			dB	
Receiver Output Voltage - Low	$V_{OL}-V_{CC}$	-2		-1.58	V	
Receiver Output Voltage - High	$V_{OH}-V_{CC}$	-1.1		-0.74	V	
Signal Detect - Asserted	P_{SDA}			-32	dBm	
Signal Detect - Deasserted	P_{SDD}	-45			dBm	
Signal Detect - Hysteresis	P_{SDH}	0.5			dB	
Signal Detect Output Voltage - Low	$V_{SDL}-V_{CC}$	-2		-1.58	V	
Signal Detect Output Voltage - High	$V_{SDH}-V_{CC}$	-1.1		-0.74	V	

Notes:

1. With BER better than or equal to 1×10^{-12} , measured in the center of the eye opening with PRBS 2⁷ -1

Pin Description

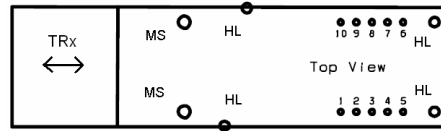

Pin No.	Pin Name	Function	Notes
MS	MS	Mounting Stubs	1
HL	HL	Housing Leads	2
1	V _{EE} R	Receiver Signal Ground	
2	V _{CC} R	Receiver Power Supply	
3	SD	Signal Detect	3
4	RD-	Receiver Data Out Bar	4
5	RD+	Receiver Data Out	4
6	V _{CC} T	Transmitter Power Supply	
7	V _{EE} T	Transmitter Signal Ground	
8	TX_Dis	Transmitter Disable Control	5
9	TD+	Transmitter Data In	6
10	TD-	Transmitter Data In Bar	6

Notes:

1. The mounting stubs are provided for transceiver mechanical attachment to the circuit board. They may also provide an optional connection of the transceiver to the equipment chassis ground.
2. The optional transceiver housing leads may be provided for additional signal grounding. These additional grounds may improve signal integrity, EMC, or ESD performance.
3. Normal Operation: Logic "1" Output; Fault Condition: Logic "0" Output.
4. No internal terminations will be provided.
5. Transmitter Disabled: $(V_{CC}T - 1.3V) < V < V_{CC}T$
Transmitter Enabled: $V_{EE}T < V < (V_{EE}T + 0.8V)$ or open circuit
6. An internal 50ohm termination will be provided.

Recommended Interface Circuit

TX DC Coupling / RX DC Coupling, PECL Signal Detect

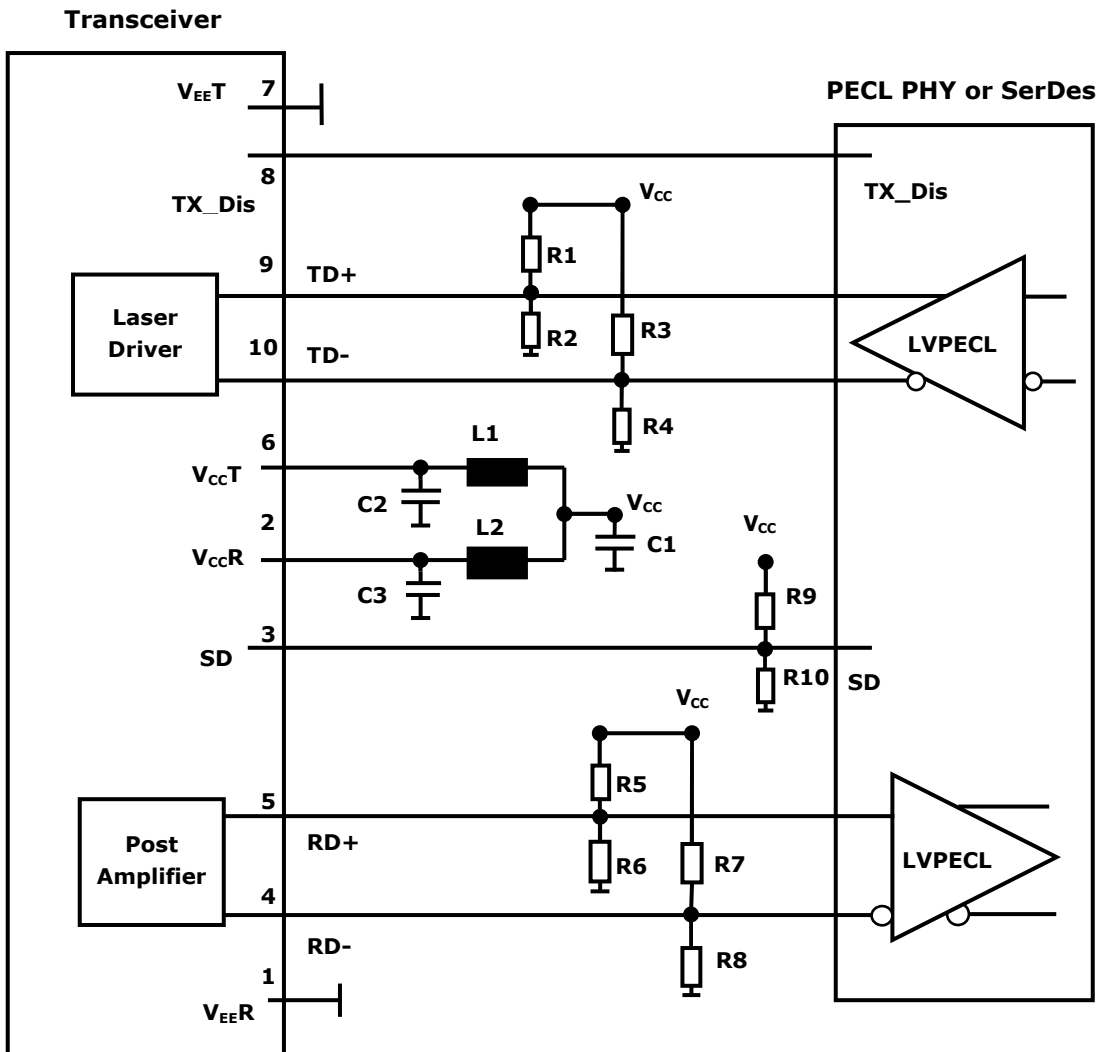

Notes:

R1/R3/R5/R7/R9=130 ohm (Depends on SerDes chip used.)

R2/R4/R6/R8/R10=82 ohm (Depends on SerDes chip used.)

C1=10uF

C2=C3=0.1uF

L1=L2=1uH

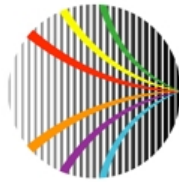

Mechanical Dimensions (Units in mm)

2x5 SFF without housing leads

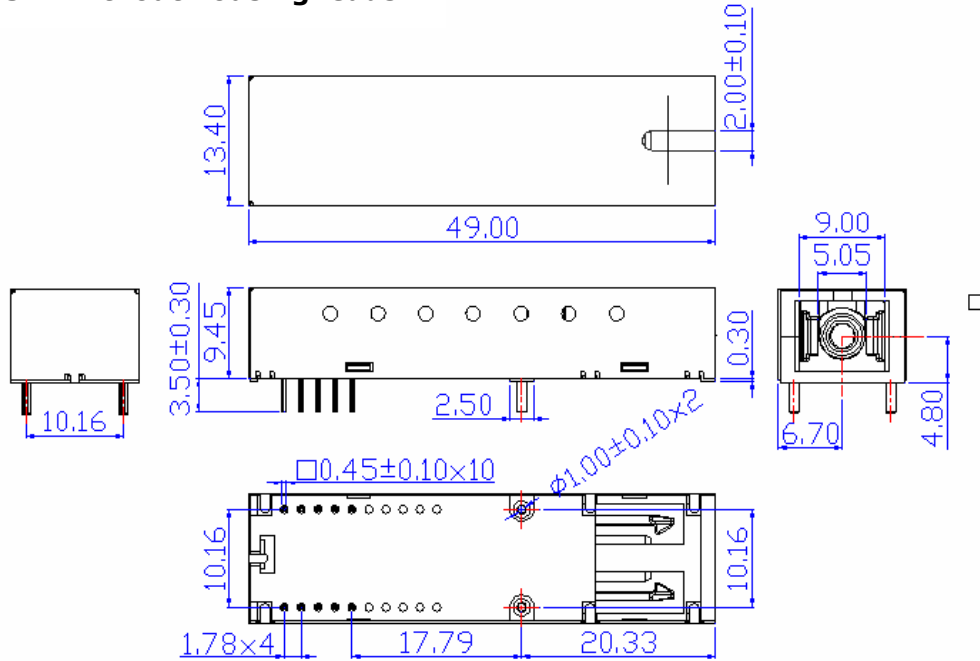

Unit : mm

All dimensions are ± 0.20 mm unless otherwise specified

2x5 SFF with housing leads

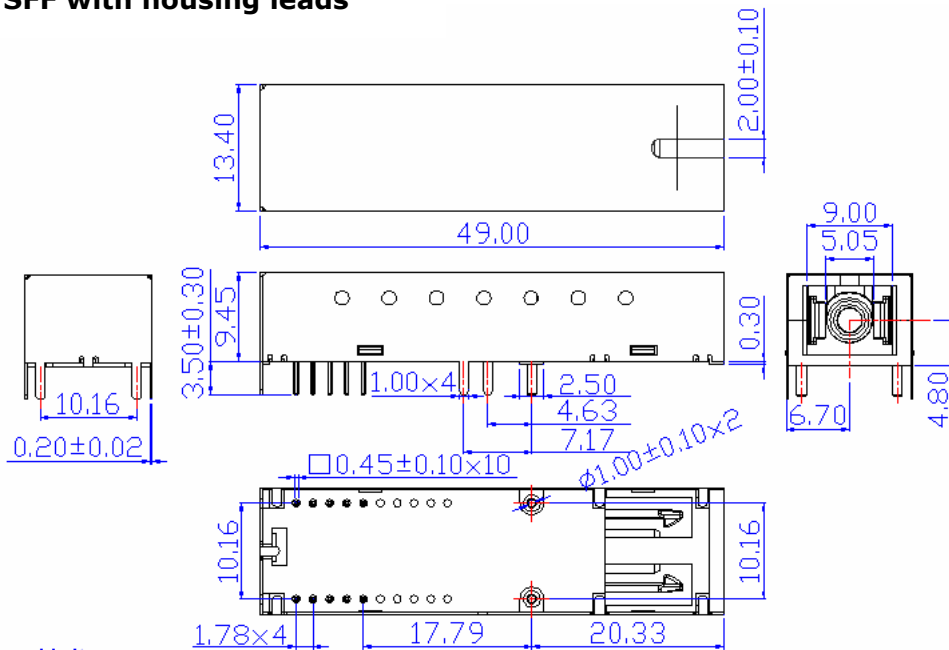

Unit : mm

All dimensions are ± 0.20 mm unless otherwise specified

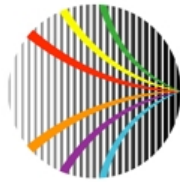

Ordering Information

AXFT-1613-x18y

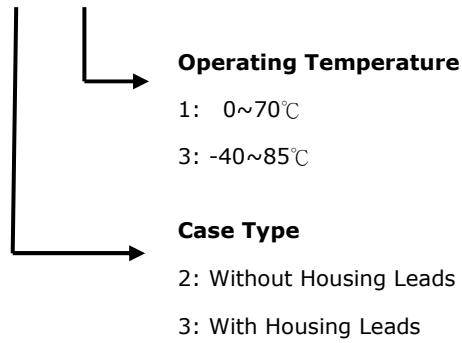

Model No.	Tx	LD	Rx	I/O	SD	Case	Link	Temp.
AXFT-1613-2181	1310nm	FP	1550nm	DC/DC	PECL	W/o Leads	20km	0~70°C
AXFT-1613-3181	1310nm	FP	1550nm	DC/DC	PECL	With Leads	20km	0~70°C
AXFT-1613-2183	1310nm	FP	1550nm	DC/DC	PECL	W/o Leads	20km	-40~85°C
AXFT-1613-3183	1310nm	FP	1550nm	DC/DC	PECL	With Leads	20km	-40~85°C