

# AXCEN

PHOTONICS CORPORATION

## **AXGE-1351 1.25Gbps Multimode 1310nm, 1x9 DSC Transceiver**



### **Product Overview**

The AXGE-1351 family of 1x9 DSC transceiver modules is specifically designed for the high performance integrated duplex data link over multimode optical fiber. These transceiver modules are compliant with the DSC Multisource Agreement (MSA). These modules are designed to provide 1000Base-SX compatible in Gigabit Ethernet applications.

The AXGE-1351 transceivers using a long wavelength (1310nm) FP laser diode enable data transmission up to 2km on a multimode optical fiber (50/125 $\mu$ m with Modal Bandwidth:500 MHz.km at 1300nm or 62.5/125 $\mu$ m with Modal Bandwidth: 500 MHz.km at 1300nm ).

### **Features**

- **Low Profile (9.8mm maximum) plastic molded package**
- **Single +3.3V power supply operation**
- **DC or AC coupling PECL level inputs and outputs**
- **PECL or TTL signal detect output**
- **Class 1 laser safety standard IEC 60825 compliant**
- **2km link on a multimode fiber**
- **Low power dissipation**

### **Applications**

- **1xFibre Channel**
- **Gigabit Ethernet**
- **High speed I/O for file server**

**Block diagram**

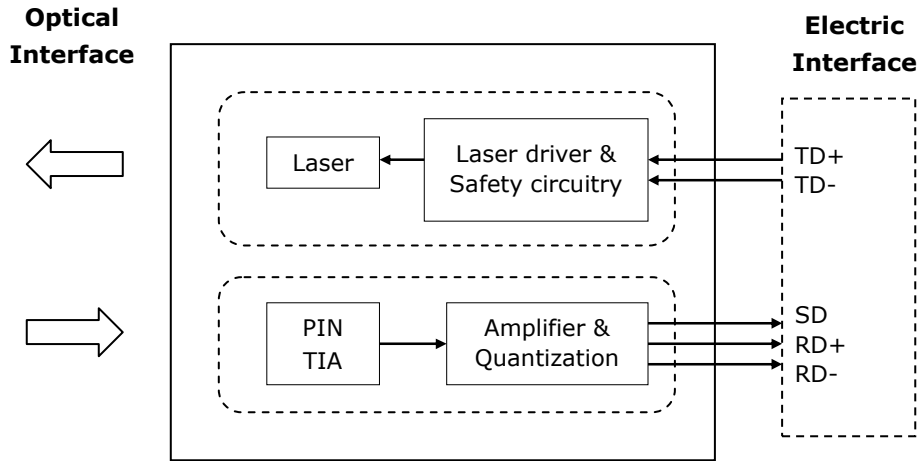

The transceiver is fundamentally consisted by two parts: transmitter and receiver. The transmitter features LVPECL differential data inputs (TD+ and TD-). The receiver features LVPECL differential data outputs (RD+ and RD-) and LVPECL for signal detect output (SD).

**Absolute Maximum Ratings**

Parameter	Symbol	Min.	Max.	Unit	Note
Storage Temperature	$T_s$	-40	+85	°C	
Supply Voltage	$V_{ccT}$ $V_{ccR}$	-0.5	4.0	V	
Storage Relative Humidity	RH	5	95	%	
Lead Soldering Temperature	$T_{ls}$		260	°C	
Lead Soldering Time	$t_{ls}$		10	sec	

**Recommended Operating Conditions**

Parameter	Symbol	Min.	Typ.	Max.	Unit	Note
Case Operating Temperature	$T_{ic}$	0		70	°C	Refer to ordering information
		-40		85		
Supply Voltage	$V_{cc}$	3.1	3.3	3.5	V	
Supply Current	$I_{TX} + I_{RX}$		150	300	mA	

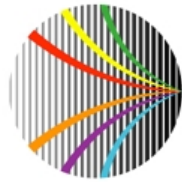

## Transmitter Electro-Optical Interface

Parameter	Symbol	Min.	Typ.	Max.	Unit	Note
Data Input Voltage – Low	$V_L-V_{CC}$	-1.81		-1.475	V	
Data Input Voltage - High	$V_H-V_{CC}$	-1.165		-0.880	V	
Optical Output Power	$P_O$	-9		-1	dBm	1
Optical Extinction Ratio	$E_R$	9			dB	
Center Wavelength	$\lambda_C$	1270	1310	1355	nm	
Spectral Width (RMS)	$\Delta\lambda$			4	nm	
Optical Rise / Fall Time	$t_r / t_f$			260	ps	2
Relative Intensity Noise	RIN			-120	dB/Hz	
Total Contributed Jitter	TJ			227	ps	

### Notes:

1. Coupling into a multimode fiber.
2. 20% to 80% value

## Receiver Electro-Optical Characteristics

Parameter	Symbol	Min.	Typ.	Max.	Unit	Note
Receiver Differential Output Voltage	RD +/-	400		2400	mV	
Receiver Overload	$P_{INMAX}$	-1			dBm	1
Receiver Sensitivity	$P_{INMIN}$			-19	dBm	1
Operating Center Wavelength	$\lambda_C$	1260		1620	nm	
Receiver Signal Detect – High	$P_{RX\_SDA}$			-19	dBm	
Receiver Signal Detect – Low	$P_{RX\_SDD}$	-35			dBm	
Receiver Signal Detect - Hysteresis	$P_{RX\_SDH}$	0.5			dB	

### Notes:

1. With BER better than or equal to  $1 \times 10^{-12}$ , measured in the center of the eye opening with  $2^7 - 1$  PRBS



## Pin Description

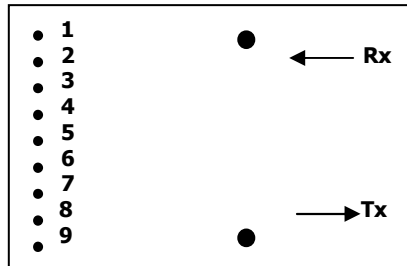

**Top View**

Pin No	Pin Name	Function	Notes
1	RxV <sub>EE</sub>	Receiver signal ground	
2	RD+	Receiver data out	
3	RD-	Receiver data out bar	
4	SD	Signal detect	
5	RxV <sub>CC</sub>	Receiver power supply	
6	TxV <sub>CC</sub>	Transmitter power supply	
7	TD-	Transmitter data in bar	
8	TD+	Transmitter data in	
9	TxV <sub>EE</sub>	Transmitter signal ground	

## Recommended Interface Circuit

### TX DC Coupling / RX DC Coupling, PECL Signal Detect

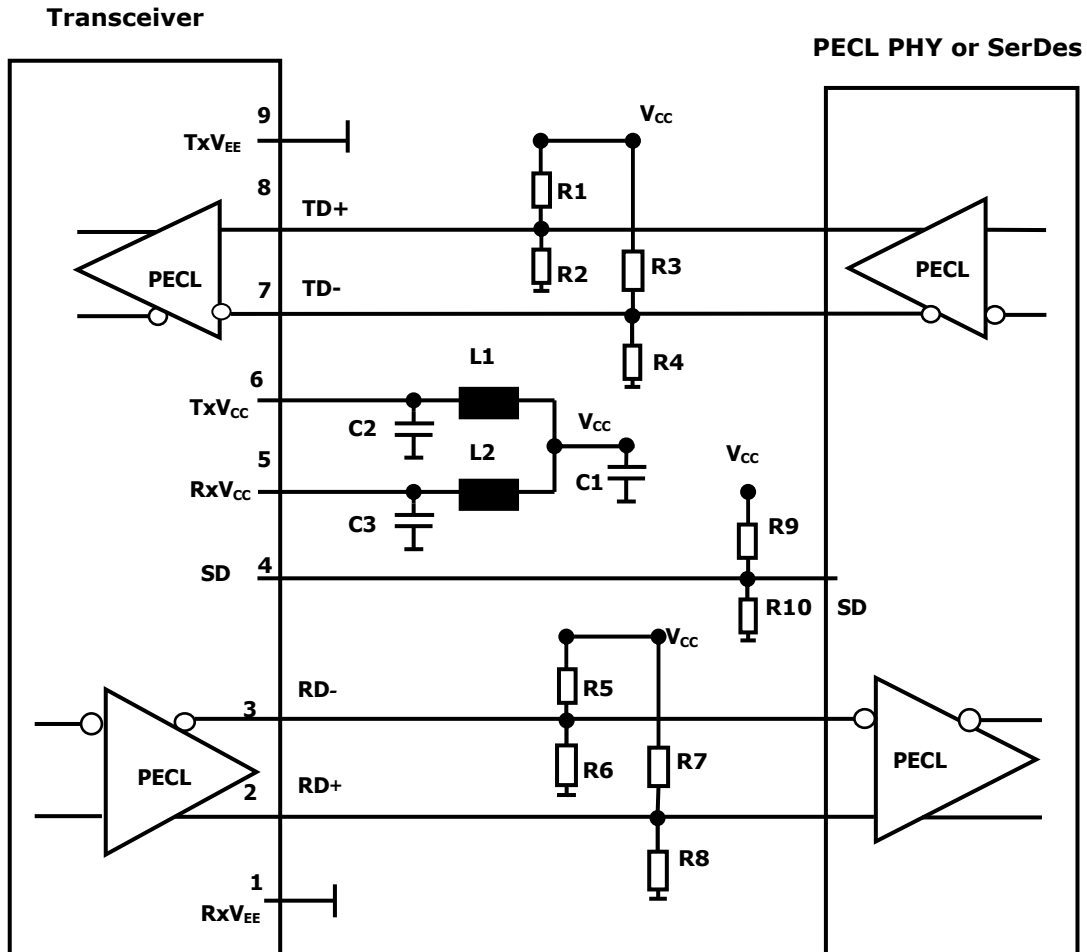

**Notes:**

**R1/R3/R5/R7/R9=130 ohm @3.3V (Depends on SerDes chip used.)**

**=82 ohm @5V (Depends on SerDes chip used.)**

**R2/R4/R6/R8/R10=82 ohm @3.3V (Depends on SerDes chip used.)**

**=130 ohm @5V (Depends on SerDes chip used.)**

**C1=10uF**

**C2/C3=0.1uF**

**L1=L2=1uH**

## TX AC Coupling / RX AC Coupling, TTL Signal Detect

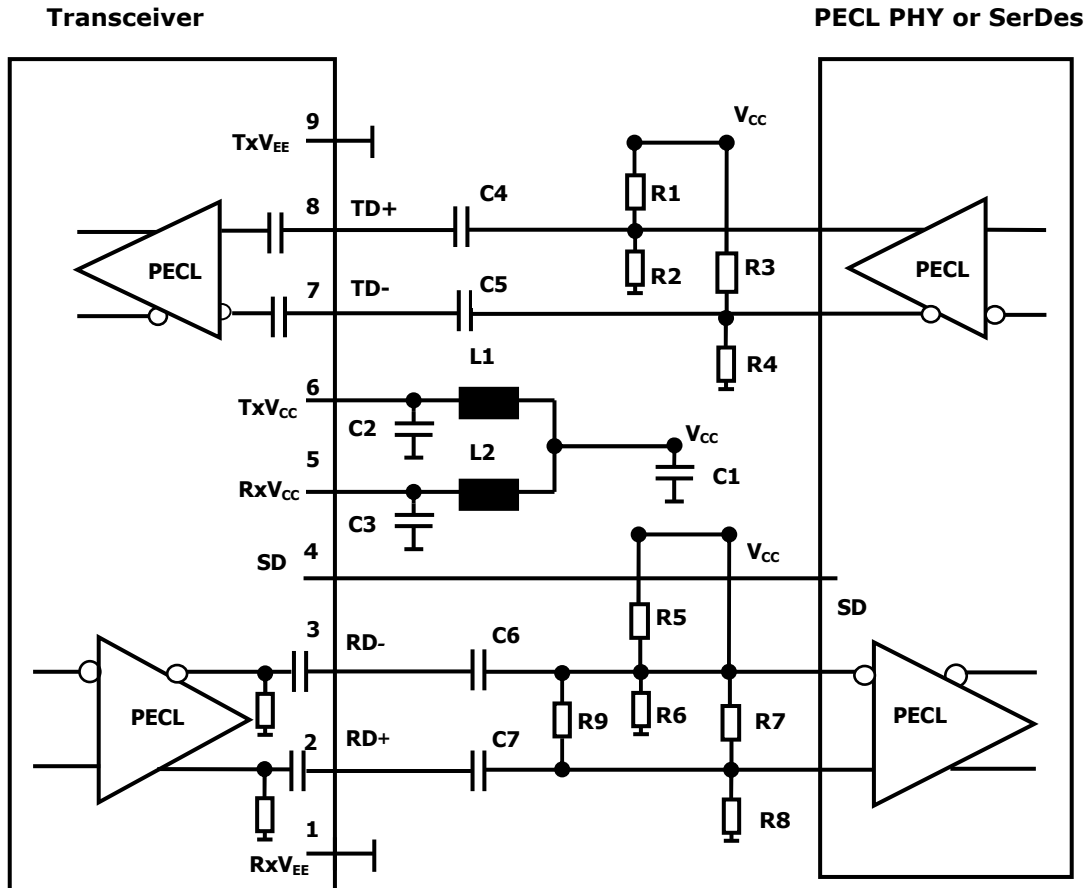

**Notes:**

**R1/R3/R5/R7/R9=130 ohm @3.3V (Depends on SerDes chip used.)**

**=82 ohm @5V (Depends on SerDes chip used.)**

**R2/R4/R6/R8/R10=82 ohm @3.3V (Depends on SerDes chip used.)**

**=130 ohm@5V (Depends on SerDes chip used.)**

**R9 =100 ohm (Depends on SerDes chip used.)**

**C1=10uF**

**C2/C3/C4/C5/C6/C7=0.1uF**

**L1=L2=1uH**

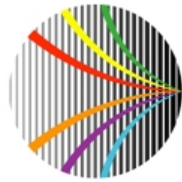

## Mechanical Dimensions (Units in mm)

### No Clipper

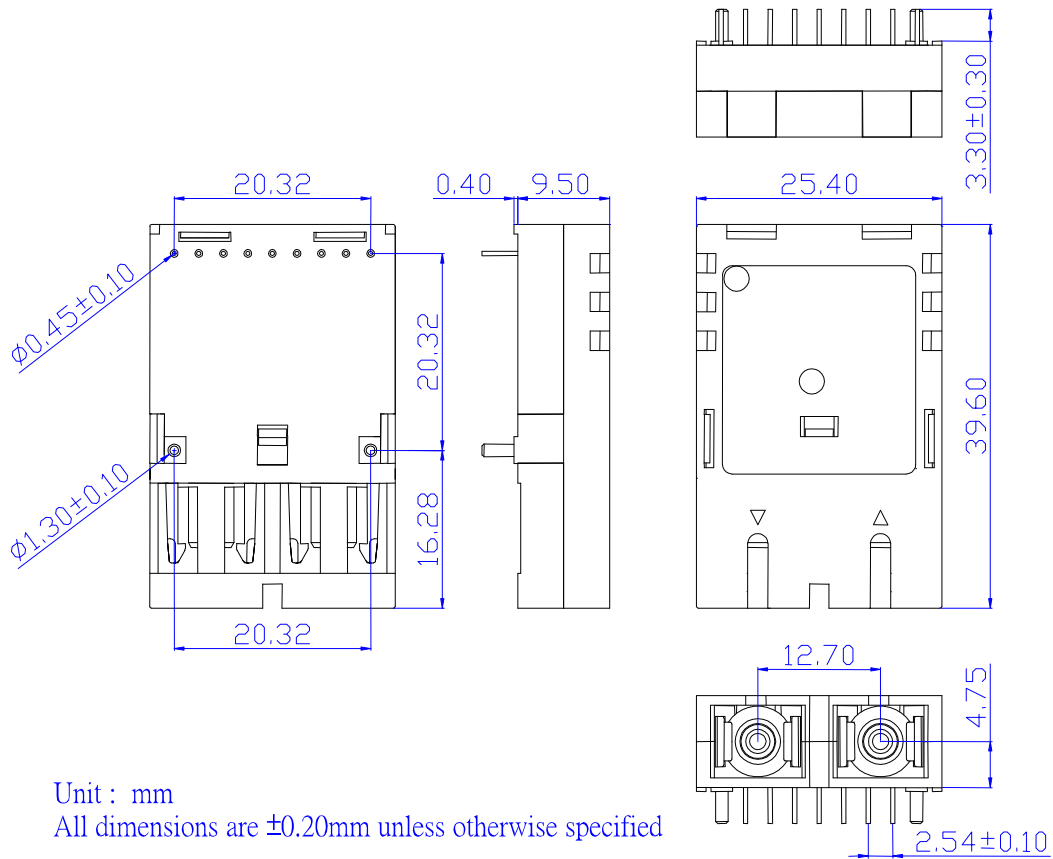

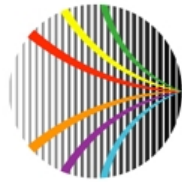

## Mechanical Dimensions (Units in mm)

### Backward Clipper

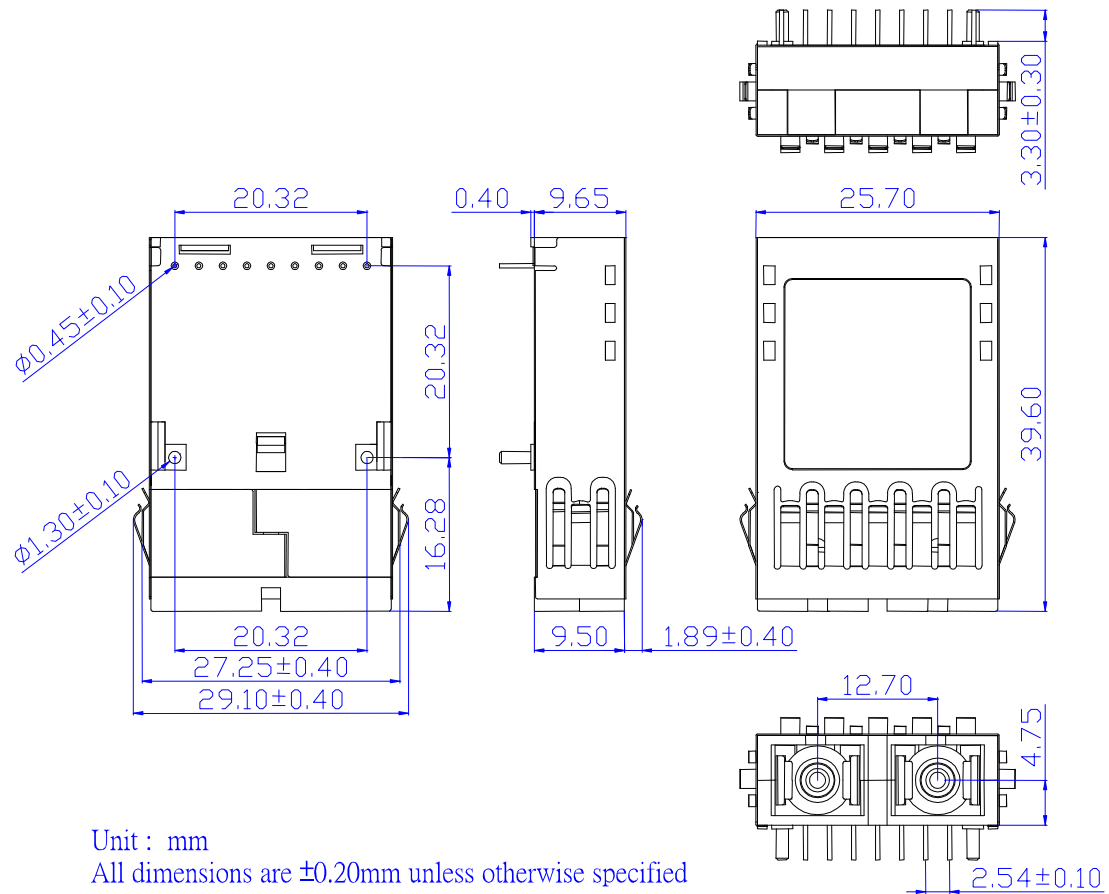

Unit : mm  
All dimensions are  $\pm 0.20$ mm unless otherwise specified

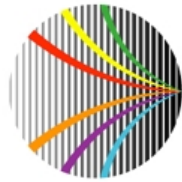

## Ordering Information

### AXGE-1351-xy2z

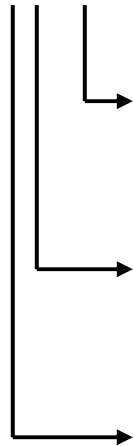

#### Operating temperature

- 1: 0~70°C
- 3: -40~85°C

#### I/O Interface

- 1: TX DC coupling / RX DC coupling, PECL Signal Detect
- 5: TX AC coupling / RX AC coupling, TTL Signal Detect

#### Clipper

- 0: No Clipper
- 1: Backward Clipper

Model No.	Wavelength	LD	Case	I/O	SD	Link	Temp.
AXGE-1351-0121	1310nm	FP	No Clipper	DC/DC	PECL	2km	0~70°C
AXGE-1351-0123	1310nm	FP	No Clipper	DC/DC	PECL	2km	-40~85°C
AXGE-1351-0521	1310nm	FP	No Clipper	AC/AC	TTL	2km	0~70°C
AXGE-1351-0523	1310nm	FP	No Clipper	AC/AC	TTL	2km	-40~85°C
AXGE-1351-1121	1310nm	FP	Bkwd Clipper	DC/DC	PECL	2km	0~70°C
AXGE-1351-1123	1310nm	FP	Bkwd Clipper	DC/DC	PECL	2km	-40~85°C
AXGE-1351-1521	1310nm	FP	Bkwd Clipper	AC/AC	TTL	2km	0~70°C
AXGE-1351-1523	1310nm	FP	Bkwd Clipper	AC/AC	TTL	2km	-40~85°C