

AXCEN

PHOTONICS CORPORATION

AXFE-1311 125Mbps Single-mode 1310nm, 1x9 DSC Transceiver



Product Overview

The AXFE-1311 family of 1x9 DSC transceiver module is specifically designed for the high performance integrated duplex data link over single-mode optical fiber. These transceiver modules are compliant with the DSC Multisource Agreement (MSA). These modules are designed to provide 100Base-FX compliant in Fast Ethernet applications.

The AXFE-1311 transceivers using a long wavelength (1310nm) light source enable data transmission up to 60km on a single-mode (9/125 μ m) optical fiber.

Features

- **Low Profile (9.8mm maximum) plastic molded package**
- **125Mbps IEEE802.3ah 100BASE-LX10 compliant**
- **155Mbps ITU-T G957 STM S-1.1/L-1.1 compliant**
- **155Mbps SONET OC-3 IR-1/LR-1 compliant**
- **Single +3.3~5V power supply operation**
- **DC coupled PECL level inputs and outputs**
- **PECL signal detect output**
- **Class 1 laser safety standard IEC 60825 compliant**
- **30/60 km link on a single-mode fiber**
- **Low power dissipation**

Applications

- **ATM switches and routers**
- **Fast Ethernet**
- **FDDI**

Block diagram

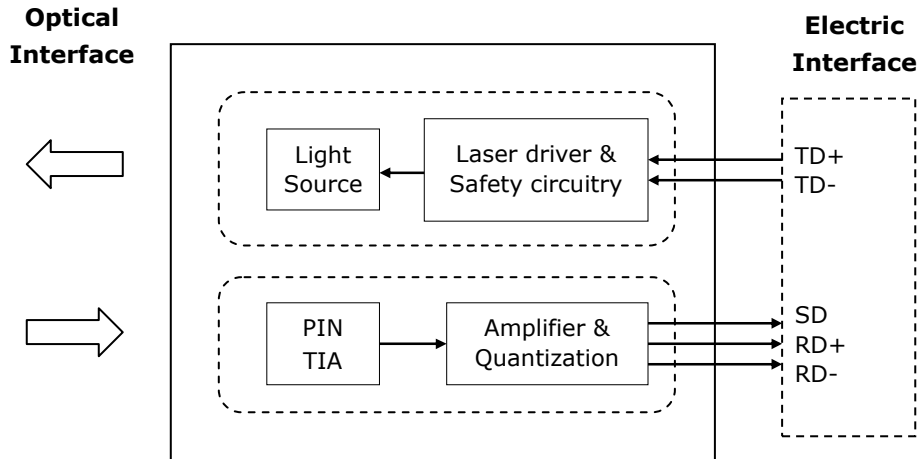

Absolute Maximum Ratings

Parameter	Symbol	Min.	Max.	Unit	Note
Storage Temperature	T_S	-40	+85	°C	
Supply Voltage	V_{CCT} V_{CCR}	-0.5	6.0	V	
Storage Relative Humidity	RH	5	95	%	
Lead Soldering Temperature	T_{Is}		260	°C	
Lead Soldering Time	t_{Is}		10	sec	

Recommended Operating Conditions

Parameter	Symbol	Min.	Typ.	Max.	Unit	Note
Case Operating Temperature	T_C	0		70	°C	Refer to ordering information
		-40		85		
Supply Voltage	V_{CC}	3.1	3.3	3.5	V	
		4.75	5.0	5.25		
Supply Current	$I_{TX} + I_{RX}$		150	300	mA	



Transmitter Electro-Optical Interface

Parameter		Symbol	Min.	Typ.	Max.	Unit	Note
Data Input Voltage – Low		V_L-V_{CC}	-1.81		-1.475	V	
Data Input Voltage - High		V_H-V_{CC}	-1.165		-0.880	V	
Optical Output Power	30 km	P_O	-15		-8	dBm	
	60 km		-5		0		
Optical Extinction Ratio	30 km	E_R	8.2			dB	
	60 km		10				
Center Wavelength	30 km	λ_C	1261		1360	nm	
	60 km		1270		1360		
Spectral Width (RMS)	30 km	$\Delta\lambda$			4	nm	
	60 km				2.5		
Optical Rise / Fall Time		t_r / t_f			2.0	ns	1
Duty Cycle Distortion		DCD			1.0	ns	
Random Jitter		RJ			0.76	ns	

Notes:

1. 10% to 90% value

Receiver Electro-Optical Characteristics

Parameter		Symbol	Min.	Typ.	Max.	Unit	Note
Receiver Overload		P_{INMAX}	-5			dBm	1
Receiver Sensitivity	30 km	P_{INMIN}			-34	dBm	1
	60 km				-35		
Operating Center Wavelength		λ_C	1270		1600	nm	
Receiver Signal Detect – High		P_{RX_SDA}			-35	dBm	
Receiver Signal Detect – Low		P_{RX_SDD}	-45			dBm	
Receiver Signal Detect - Hysteresis		P_{RX_SDH}	1.0			dB	
Receiver Signal Detect Voltage - Low		$V_{SDL}-V_{CC}$	-2		-1.58	V	
Receiver Signal Detect Voltage - High		$V_{SDH}-V_{CC}$	-1.1		-0.74	V	

Notes:

1. With BER better than or equal to 1×10^{-12} , measured in the center of the eye opening with $2^7 - 1$ PRBS



Pin Description

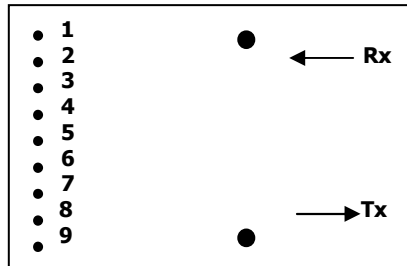

Top View

Pin No	Pin Name	Function	Notes
1	RxV _{EE}	Receiver signal ground	
2	RD+	Receiver data out	
3	RD-	Receiver data out bar	
4	SD	Signal detect	
5	RxV _{CC}	Receiver power supply	
6	TxV _{CC}	Transmitter power supply	
7	TD-	Transmitter data in bar	
8	TD+	Transmitter data in	
9	TxV _{EE}	Transmitter signal ground	

Recommended Interface Circuit

TX DC Coupling / RX DC Coupling, PECL Signal Detect

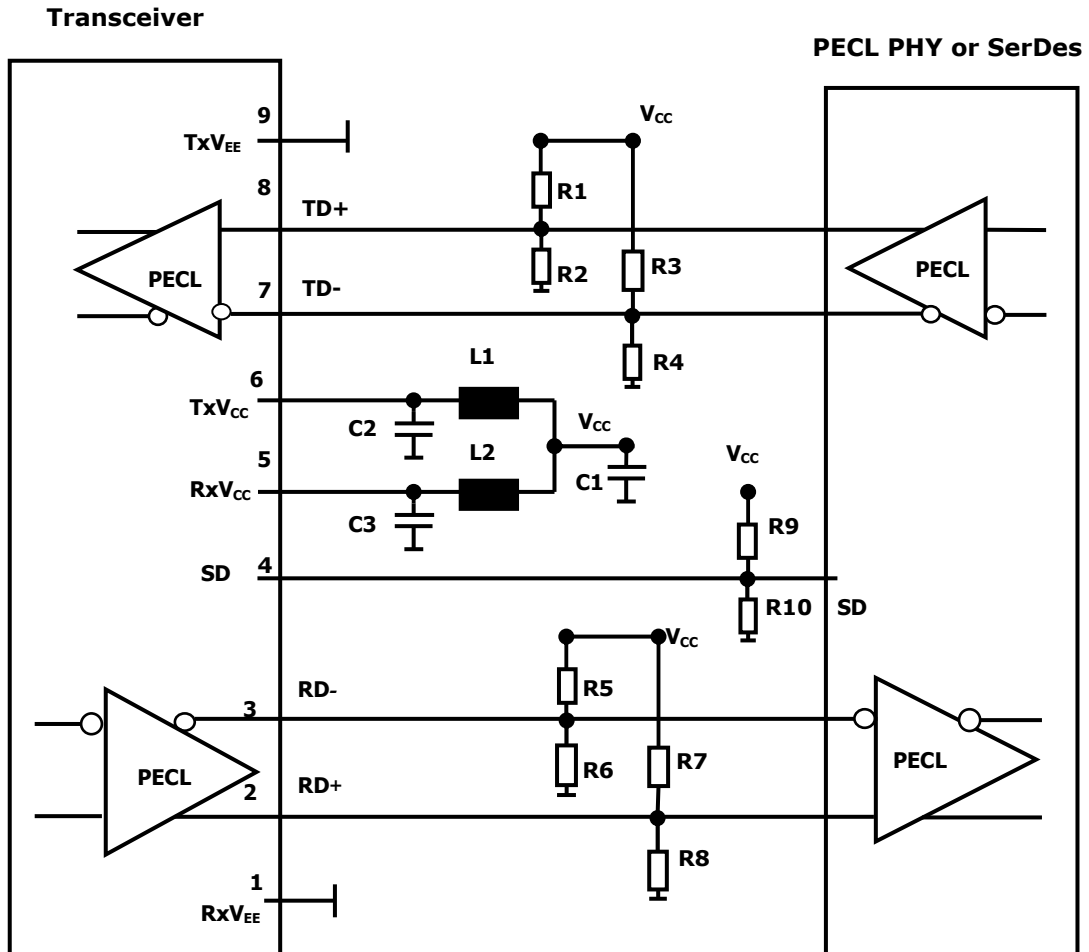

Notes:

R1/R3/R5/R7/R9=130 ohm (3.3V) or depends on SerDes chip used.

=82 ohm (5V) or depends on SerDes chip used.

R2=R4=R6=R8=R10=82 ohm (3.3V) or depends on SerDes chip used.

=130 ohm (5V) or depends on SerDes chip used.

C1=10uF

C2=C3= C4=C5=C6=C7=0.1uF

L1=L2=1uH

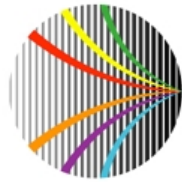

Mechanical Dimensions (Units in mm)

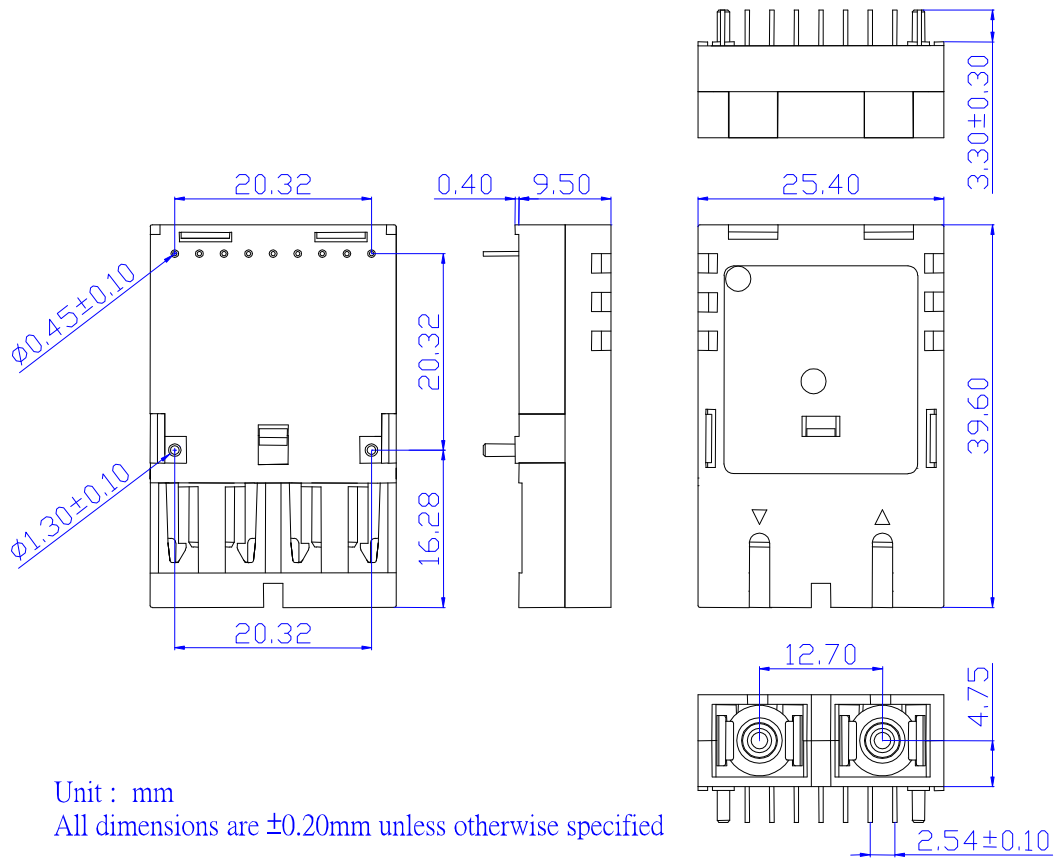

Unit : mm

All dimensions are ± 0.20 mm unless otherwise specified

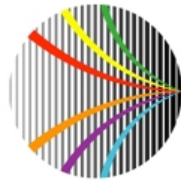

Ordering Information

AXFE-1311-01xy

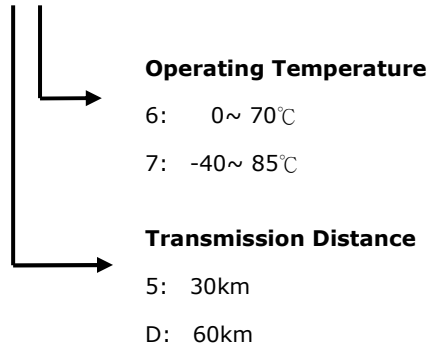

Model No.	Wavelength	LD	I/O	SD	Link	Temp.
AXFE-1311-0156	1310nm	FP	DC/DC	PECL	30km	0~70°C
AXFE-1311-0157	1310nm	FP	DC/DC	PECL	30km	-40~85°C
AXFE-1311-01D6	1310nm	FP	DC/DC	PECL	60km	0~70°C
AXFE-1311-01D7	1310nm	FP	DC/DC	PECL	60km	-40~85°C

NOTE:

Distances are indicative only. Attenuation of 0.40 dB/km is used for the link length calculations. To calculate a more precise link budget based on specific conditions in your application, please refer to the Optical Specifications in Page#3.